

1991 FORD EXPLORER





THE NEW EXPLORER 4-DOOR

The look of Explorer is contemporary and aerodynamic. It's a shape of style and function you would expect from Ford Motor Company, a world leader in automotive design.

Wraparound front bumpers with integral spoiler, flush-mounted glass, and limousine-style doors with hidden drip rail system are among Explorer's many air-flow management features.

To appreciate our finest achievement in designing the new Explorer 4-Door, however, you'll have to look inside — at all the comforts and conveniences that plenty of space affords.

Here, we saw an opportunity to break new ground. And we made the most of it. We went to great lengths, and widths, to provide much more room for people and space for cargo than we ever had before in a compact utility vehicle.

What we created is a family-size 4-door compact utility whose interior is more spacious than any other in its class. And the four-door Explorer is the only compact utility vehicle that offers the option of six-passenger seating.

The new Explorer 4-Door. Here is a line of V-6-powered 4x2 and 4x4 vehicles with a combination of style, performance, space and comfort that gives the term "compact utility" a new dimension.



The roomy Explorer 4-Door features a versatile 60/40 rear split bench seat.

The Eddie Bauer Explorer with optional front sport bucket seats with leather seating surfaces in Light Sandalwood. Some equipment shown on these pages is optional.



1991 FORD EXPLORER

An explorer, by definition, is one who travels in search of the new and the exciting.

Explorer. We can think of no other name that could better capture the design and engineering capabilities of our next-generation compact utility vehicle.

Certainly no other name could better express the spirit of individuality and adventure possessed by those who would drive it.

To the explorer in you, we introduce the Ford Explorer. Family-size 4-door and sporty 2-door models, each offering three trim levels in 2- or 4-wheel drive.

Let one take you in pursuit of your adventures.

Eddie Bauer Explorer
4-Door in unique two-tone
Twilight Blue Clearcoat
Metallic and Light Sandal-
wood. Some equipment
shown is optional.







EXPLORER 4-DOOR DESIGN

Here, at last, is a compact utility vehicle with honest family-size comfort. Seating for five is standard. Or accommodate six with the optional split bench front seat.

It's no accident that the Explorer 4-Door's long 111.9-in. wheelbase contributes to the ample measure of rear seat leg room that no competitor can match. Everyone can enjoy the comfort that Explorer's best-in-class space provides.

The Explorer 4-Door also provides more cargo space than the leading competitors — 81.6 cu. ft. plus a 6-ft.-long flat cargo floor with the rear seat backs lowered.

The Explorer 4-Door is not only spacious. It's also easy to get into and out of, thanks to a low step-in height — the first of many car-like conveniences you'll experience.

And, equally important, Explorer has the power and handling and the ergonomic seating, instruments and controls to satisfy the driving enthusiast within you.

Drive the new Explorer 4-Door and open new doors to greater travelling comfort, enjoyment, and adventure.



The Explorer 4-Door offers a spacious interior and a low step-in height for easy entry and exit.



Six-passenger seating with the split bench front seat option is an exclusive Explorer 4-Door feature. It's available with the XL and XLT trim levels. Five-passenger seating is standard.

Ergonomic instrument cluster includes a tachometer; engine temperature, oil pressure, fuel level and volt-meter gauges. Instrument panel also has four air vent registers plus front door window demisters.

On a single steering column-mounted lever are controls for turn signals, constant-speed and interval windshield wipers, windshield washer, headlamp high-beams, and flash-to-pass feature.

Front and rear outboard seating positions have lap and shoulder belts with automatic retractors. Center seating positions have lap belts.

Optional 4-speed automatic transmission shift lever is mounted on the steering column, providing greater leg room.

The versatile 60/40 split bench rear seat lets you lower one or both seat backs to suit passenger- and cargo-carrying needs.

The Explorer 4-Door has 81.6 cu. ft. of cargo space plus a 72.9-in. long cargo load floor (with rear seat backs lowered).

Rear seating compartment has its own heat duct.

Four cargo tie-down hooks are standard. A cargo net is included in XLT and Eddie Bauer trim levels.

The standard full-size spare tire is mounted to the frame beneath the load floor. This design increases cargo space.



In a pod to the right of the instrument cluster are, from top to bottom: (1) the push-button control module for the Touch Drive electric shift transfer case, standard in Explorer 4x4 models; (2) the stereo system; and (3) the heating/cooling/defroster system controls.



Features of the optional power equipment group (power door locks, windows, and electric remote-control mirrors) are located on a special ergonomic door-mounted panel. Tactile controls, easily identified by touch alone, are designed with a "bump" at one end ("on") and a "dimple" at the other end ("off").

EDDIE BAUER 4-DOOR

When the time came to select a name for the best of the Explorers, we could not have picked one more expressive of "top of the line" than Eddie Bauer, the name widely known for quality outdoor apparel.

The Eddie Bauer has its own two-tone paint treatment. And it's outfitted with P235 OWL all-terrain tires on luxury aluminum wheels; power windows, door locks, and electric remote-control mirrors; luggage rack; speed control/tilt wheel; rear wiper/washer/defroster; and tilt-up open air roof (Preferred Equipment Package feature).

What's more, a two-piece luggage set is shipped directly to you from Eddie Bauer. And you get the "Ford Care" extended maintenance and limited warranty with coverage up to 24 months or 24,000 miles in addition to the 6-year/60,000-mile powertrain warranty. Ask for a copy of these limited warranties at your Ford Dealer.

Eddie Bauer Explorer interior with premium cloth captain's chairs in Light Sandalwood.

Air conditioning and electronic premium AM/FM stereo with cassette tape player are included in the Eddie Bauer Preferred Equipment Package. You can upgrade the stereo to the 9-speaker Ford JBL audio system with compact disc player, an Eddie Bauer exclusive in the Explorer lineup.





Eddie Bauer Explorer
4-Door in unique two-tone
Sandalwood Clearcoat
Metallic and Light Sandal-
wood. Some equipment
shown on these pages is
optional.

XLT AND XL 4-DOOR

Chances are, a good number of people in the market for a family vehicle will bypass the road travelled by typical sedans and wagons.

Their active, varied life styles call for a vehicle of uncommon flexibility. So they'll choose the new Explorer 4-Door — a vehicle that's as much at home on a suburban street as at a wilderness campsite.

The Explorer 4-Door XLT and XL models are especially well-suited for families. Along with their spaciousness, versatility, smooth 4-liter V-6 performance and the choice of 4x2 or 4x4 model, both offer great value in their lists of comfort and convenience features.

Explorer XL comes with reclining front high-back bucket seats, courtesy light group (glove box, ashtray and engine compartment lights), the two-way liftgate that lets you raise the entire liftgate or just

the window, AM/FM stereo system, interval wipers with variable speed settings, plus analog gauges (tachometer, voltmeter, fuel, engine temperature and oil pressure). A trip odometer, too. Among the XL 4x4's features is the Touch Drive transfer case which delivers the added traction and security of 4-wheel drive at the touch of a button on the instrument panel.

Explorer XLT is even more impressive. Standard are cloth reclining captain's chairs, the power equipment group (power windows, door locks, and electric remote mirrors), auxiliary side sun visors, deluxe reading light/dome lamp, speed control and tilt steering wheel, and deep-dish cast aluminum wheels. Plus deluxe two-tone paint, air conditioning, and electronic premium AM/FM stereo with cassette tape player in the XLT Preferred Equipment Package.

Both XL and XLT provide standard seating for five passengers, or six-passenger seating with the 60/40 split bench front seat — an option that isn't available in any other compact utility vehicle.

What's more, in the Explorer XLT you can order optional leather seating surfaces on sport bucket seats with power lumbar control, and the outstanding sound fidelity of the 9-speaker Ford JBL audio system with cassette tape player.

Explorer XLT 4-Door interior in Crystal Blue. The optional 60/40 split bench front seat (shown) makes the Explorer 4-Door the only six-passenger vehicle in its class.





Explorer XLT 4-Door in deluxe two-tone Silver Clearcoat Metallic and Raven Black.

Explorer XL 4-Door in Crystal Blue Clearcoat Metallic. Some equipment shown on these pages is optional.

EXPLORER ENGINEERING

Ford Explorer is engineered with emphasis on all-around performance — power, handling and braking — to satisfy the wide variety of personal uses for which this new generation of 4-door and 2-door compact utility vehicles is designed.

Multi-port fuel-injected 4.0L V-6 is controlled by Ford's EEC-IV computer. EEC-IV continuously "fine-tunes" the engine; controls fuel-air mixture and adjusts spark timing to optimize power and efficiency.

Twin-I-Beam (4x2) and Twin-Traction Beam (4x4) front suspension systems feature an axle/coil spring assembly for each wheel, providing independent wheel action for ride smoothness and control.

Front coil springs and rear 2-stage multi-leaf springs are computer-selected to match precisely the vehicle's passenger- and load-carrying requirements.

Nitrogen gas-pressurized shock absorbers contribute to a smooth and controlled ride by suppressing the foaming action of the hydraulic fluid caused by rough or bumpy road conditions.

Front and rear stabilizer bars, connecting the axles to the frame, function as torsion bars to help improve handling.

Recirculating ball-type steering system is power-assisted; provides easy steering in low-speed turning maneuvers.

A 5-speed manual transmission with close-ratio gearing and synchronized reverse gear is standard. A 4-speed automatic with steering column-mounted shift is optional. Both feature overdrive high gear.

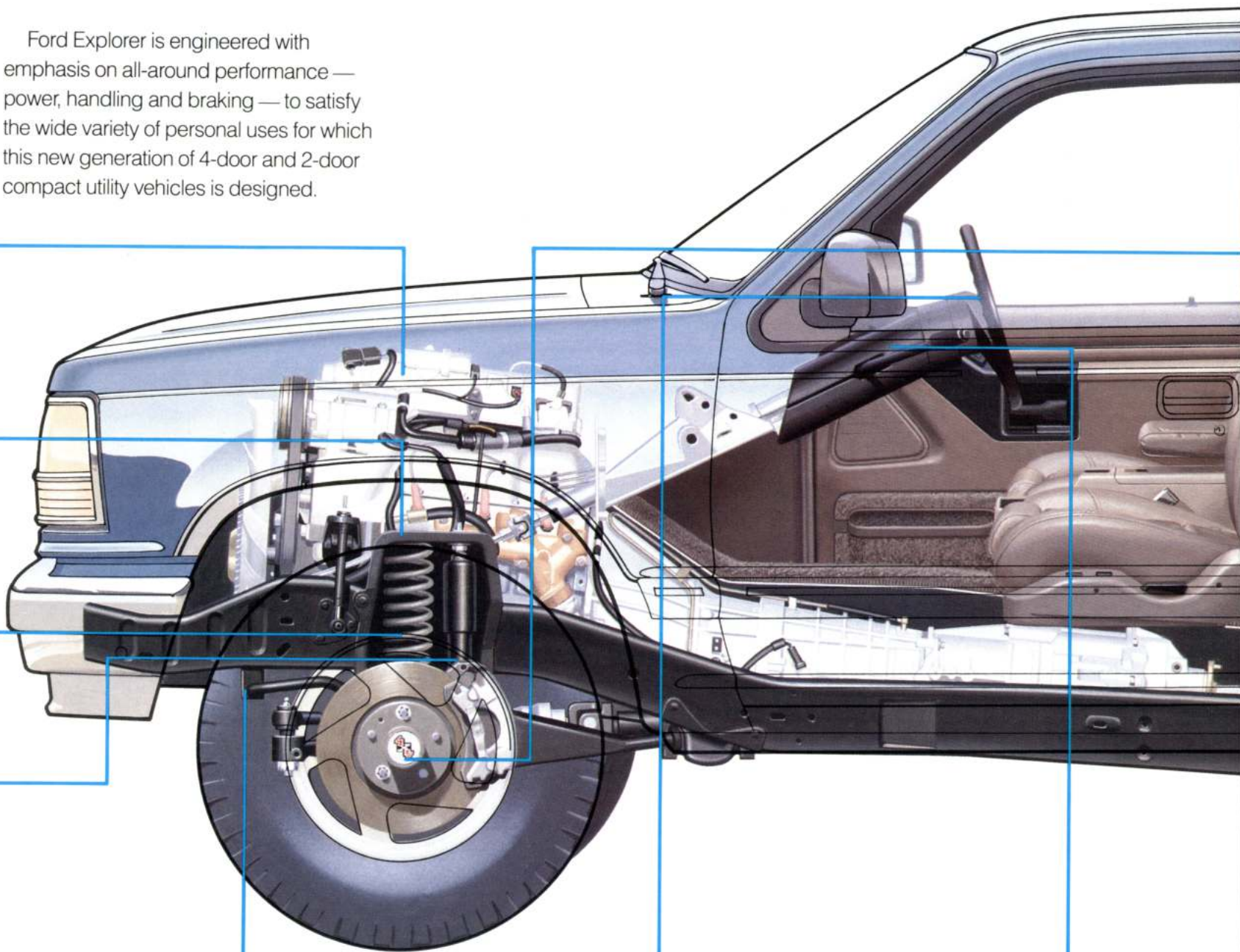



The ladder-type frame features full-length, heavy gauge channel side rails and five crossmembers, providing a solid foundation for the vehicle body and strength for trailer towing.

The electronic rear anti-lock brake system is designed to inhibit complete rear wheel lockup and help you come to a straight stop under most operating conditions when travelling in 2-wheel drive.

Tires are of all-season or all-terrain design depending on model (see page 25). All-season tread provides excellent traction under various weather and road conditions. All-terrain tread provides excellent traction as well, for both on and off-road travel.

4x4 model has standard auto-locking front hubs with Touch Drive electric 2-speed shift transfer case. Features include: on-the-fly shifting from 2WD to 4WD-High and back at any speed; an electromagnetic clutch that spins up the drive system from zero to driving speed in milliseconds; and electric interlock 4WD-Low shift protection. Manual-locking front hubs with manual-shift transfer case are optional. Skid plates are included with both automatic and manual systems.

Explorer features 2½ mile-per-hour front wraparound and rear step bumpers. The rear bumper has a 3,500-lb. towing capacity. With a frame-mounted weight-distributing hitch, Explorer can tow 5,700 pounds (reduced by passenger and cargo weight in the towing vehicle).

THE NEW EXPLORER 2-DOOR





SPORT 2-DOOR

At the crossroads where the spirit of the independent life style and the desire for driving adventure meet, there is the new Explorer Sport 2-Door.

The Explorer aero design takes on a distinctly dramatic style with black-out treatment all-around, black lower two-tone paint, and privacy glass rear quarter windows. The P235 OWL all-terrain tires* are on deep-dish cast aluminum wheels.

Inside, cloth captain's chairs with console, the power equipment group and air conditioning are included.* A leather-wrapped steering wheel, too, and more.

The power of the high-torque 4.0L port fuel-injected V-6 reaches pavement by way of a 3.73:1 performance rear axle.* Explorer Sport has the muscle, and the handling performance, to take on most on-road or 4x4 off-road challenges.

*Preferred Equipment Package features.

Explorer Sport 2-Door interior with optional cloth sport bucket seats in Scarlet Red.





Explorer Sport 2-Door in unique two-tone Wild Strawberry Clearcoat Metallic and Black. Some equipment shown on these pages is optional.

EDDIE BAUER AND XL 2-DOOR

Whether you're commuting to work or getting away for the weekend, regardless of where you're going, you should derive as much enjoyment as possible from the driving experience.

With this "driver-oriented" philosophy we designed the Explorer 2-Door's contemporary aero styling and modern interior, and we engineered its exciting all-around performance.

Inside, we outfitted the Explorer 2-Door models with firm and supportive seating for four passengers, ergonomic instruments and controls, and versatile 50/50 split-folding rear seats, to name just a few of the many standard features listed on page 25.

To further make the practical side of the sport/utility equation as attractive as the fun side, we gave the Explorer 2-Door a surprising 69.5 cu. ft. of maximum cargo space. With the rear seat backs raised, you have 32.6 cu. ft.

Finally, to satisfy your personal style and your equipment needs, we created a line of three well-equipped trim levels.

Choose the youthful Explorer Sport (pages 18-19); or, featured here, the luxury-sport Eddie Bauer Explorer or the fun-tough Explorer XL. All share the same high standards of design and engineering performance, and quality.



The top-of-the-line Eddie Bauer Explorer 2-Door in unique two-tone Hunter Green Clearcoat Metallic and Light Sandalwood. Some equipment shown on these pages is optional.



**Explorer XL 2-Door in Silver
Clearcoat Metallic.**

**Eddie Bauer Explorer
2-Door interior with stan-
dard reclining captain's
chairs in Light Sandalwood.**

CUSTOMER-DRIVEN DESIGN

At Ford, our philosophy dictates that every detail of design must contribute to "customer satisfaction." Examine the new Explorer up close and you'll find many examples of purposeful automotive design.

The limousine-style doors, for instance, demonstrate that function is every bit as important as style. The wrapover roof design with hidden drip rail system not only contributes to Explorer's contemporary styling, but is also an important aerodynamic feature.

Another notable feature is the design of the versatile liftgate that opens to Explorer's spacious cargo compartment. Raise the entire liftgate or just the window.

How could we provide a "full-size" spare tire as standard equipment without encroaching on cargo space? We could have mounted it to an outside swingaway carrier. But instead, for Explorer, we used a better design: the tire is mounted in a carrier between the frame rails, out of the way but easily reached and removed when needed.

In Explorer, as in every car and light truck we build, every detail — whether it be a major engineering component or a single switch on the instrument panel — is important in our "customer-driven" approach to design.



Four cargo tie-down hooks are standard in every Explorer. In the XLT and Eddie Bauer trim levels, a cargo net is also included.



The limousine-style doors merge into the roofline. The hidden drip rail system eliminates the conventional drip moldings; the flush door glass reduces the gap between the glass and the window frame, helping to lessen air resistance and wind noise.



Push-button controls for the standard Touch Drive electric shift transfer case (in the 4x4 model) are on the instrument panel — a more convenient arrangement than the floor-mounted shift found in other 4x4 compact utility vehicles.



You can access Explorer's spacious cargo compartment from the rear by raising the entire steel liftgate or just the window. Both open with the assist of pneumatic struts. A pull-down handle is included.



The standard full-size spare tire is mounted to the frame between the rear frame rails. This design allows for increased cargo space. The tire lowers easily with a crank mechanism.

With its body-on-frame construction and high-torque V-6 power, Explorer is a great vehicle for towing a boat or camper/trailer. General towing information is provided on page 15.

PREFERRED EQUIPMENT PACKAGES

Preferred Equipment Packages are groups of popular features. They not only make Explorer an outstanding value, but also make it easy for you to order a vehicle equipped the way you want it. Simply select the trim level with the Preferred Equipment Package you want from the chart on the following page.

(A) From top to bottom: full wheel cover; deluxe steel wheel with trim rings; deep-dish cast aluminum wheel; and luxury aluminum wheel. See page 25 for application by trim level.

(B) The optional tilt-up open air roof can be flipped open or removed (included in Eddie Bauer package). Shown also is the optional roof luggage rack (standard on Eddie Bauer).

(C) The optional rear window wiper/washer/ defroster (standard on Eddie Bauer) clears the window of rain, mist or ice. When shut off, the wiper lifts off the glass and rests on the bottom window molding.

To further personalize your new Ford Explorer, choose from the wide selection of options available individually.

The Explorer Sport, XLT and Eddie Bauer Preferred Equipment Packages offer special savings on those features with the "■" designation.

The top-of-the-line Eddie Bauer Explorer, for example, includes air conditioning, the electronic premium AM/FM stereo system with cassette tape player and digital clock, as well as the functional and attractive tilt-up open air roof.

Compared with the manufacturer's suggested retail prices for these desirable features if they were to be purchased separately, the package discount is the equivalent of getting certain equipment at no extra cost.

Features in the Preferred Equipment Packages are subject to change over the course of the year. For the latest information on package contents and discounts, consult your Ford Dealer.



A



B



B



C

PREFERRED EQUIPMENT PACKAGES ■ = Included in Package S = Standard O = Optional	2-Door Model			4-Door Model		
	XL 930A	Sport 931B	Eddie Bauer 932B	XL 940A	XLT 941B	Eddie Bauer 942B
Air conditioning	0	■	■	0	■	■
Deluxe two-tone paint (may be deleted from XLT)					■	
Deep-dish cast aluminum wheels	0	S	0	0	S	0
Electronic premium AM/FM stereo with cassette tape player and digital clock	0	0	■	0	■	■
4.0L V-6 engine/5-speed manual overdrive transmission	S	S	S	S	S	S
4.0L V-6 engine/4-speed automatic overdrive transmission	0	0	0	0	0	0
California emissions system	0	0	0	0	0	0
High altitude principal use	0	0	0	0	0	0
P225 RBL all-season tires	S	S		S	S	
P235 OWL all-terrain tires	0	■	S	0	0	S
Knitted vinyl bucket seats	S	S		S		
Cloth captain's chairs with required floor console (may be deleted from Sport and replaced with vinyl bucket seats)	0	■		0	S	
Cloth sport bucket seats with power lumbar control and with required floor console		0			0	
Cloth 60/40 split bench seat				0	0	
Cloth Eddie Bauer captain's chairs with power lumbar control and floor console			S			S
Sport bucket seats with power lumbar control and leather seating surfaces		0	0		0	0
Performance axle	0	■	0	0	0	0
Super engine cooling	0	0	0	0	0	0
Privacy glass™ rear quarter windows	0	S	S			
Engine block heater	0	0	0	0	0	0
Manual locking hubs (1)	0	0	0	0	0	0
License plate bracket	0	0	0	0	0	0
Light group (2)	0	S	S	S	S	S
Bodyside moldings	0			0	S	
Power equipment group (3)		■	S		S	S
Luggage rack (100-lb. capacity)	0	0	S	0	0	S
Tilt-up open air roof (may be deleted from Eddie Bauer)		0	■	0	0	■
Speed control/tilt steering wheel	0	0	S	0	S	S
Deluxe tape stripe					0	
Trailer towing package (4)	0	0	0	0	0	0
Deluxe steel wheels with trim rings (5)	0			0		
Luxury aluminum wheels		0	S		0	S
Rear window wiper/washer/defroster	0	0	S	0	0	S
Electronic AM/FM stereo radio with digital clock and four speakers	S	S	S	S	S	S
Electronic AM/FM stereo radio with cassette tape player, digital clock and four speakers	0	0	0	0	0	0
Ford JBL audio system with cassette tape player		0	0		0	0
Ford JBL audio system with compact disc player			0			0
Radio credit option (deletes standard radio)	0	0	0	0	0	0

(1) Replaces standard automatic locking front hubs and Touch Drive transfer case. (2) Includes glove box light, ashtray light and engine compartment light. (3) Includes power windows, power door locks, electric remote-control mirrors, and high-series door trim. May be deleted from 2-Door Sport package without loss of credit. (4) Includes wiring harness, heavy-duty flasher, and super engine cooling. (5) Optional on XL 4x2. Standard on XL 4x4.

MAJOR STANDARD FEATURES

EXTERIOR

- Aero-design halogen headlamps with bright frames (XL, XLT, Eddie Bauer); black frames (Sport)
- Grille: bright (XL, XLT, Eddie Bauer); black (Sport)
- Front bumper: bright with rub strip and spoiler (XL, XLT, Eddie Bauer); black with rub strip and spoiler (Sport)
- Rear trailer-tow bumper: bright with rub strips (XL, XLT, Eddie Bauer); black with rub strips (Sport)
- Tinted windshield and side/rear windows
- Flip-open opera windows (2-door models)
- Foldaway mirrors: black door-mounted (XL, Sport); electric remote-control (XLT, Eddie Bauer)
- Special paint treatment: unique two-tone with Light Sandalwood tape stripes (Eddie Bauer); black sport two-tone (Sport)
- 2-way liftgate: raise the entire liftgate or just the rear window
- Roof rack (Eddie Bauer)
- Wheel trim: full covers (XL 4x2); deluxe steel wheels with trim rings (XL 4x4); deep-dish cast aluminum wheels (Sport, XLT); luxury aluminum wheels (Eddie Bauer)
- Full-size spare tire, frame-mounted

INTERIOR

- Front seat back recliners
- Rear split bench seats: 2-passenger 50/50 (2-door); 3-passenger 60/40 (4-door)
- Ergonomic instrument cluster with tachometer; fuel, engine temperature, voltmeter and oil pressure gauges; trip odometer
- Instrument cluster appliqué: black (XL); color-keyed (Sport, XLT, Eddie Bauer)
- Side window demisters on instrument panel
- Stalk-mounted controls for turn signals, windshield wipers/washer, high beams, flash-to-pass feature
- Interval windshield wipers
- Steering wheel: black vinyl (XL); black leather-wrapped (Sport, XLT, Eddie Bauer)
- Visors: Driver and passenger with RH visor mirror (XL); illuminated driver and passenger visor mirrors plus auxiliary side visors (Sport, XLT, Eddie Bauer)
- Cargo area light
- Cargo area cover (XLT, Eddie Bauer)

TECHNICAL

- 4.0L V-6 engine
- Multi-port electronic fuel injection, EEC-IV computer
- 5-speed manual overdrive transmission
- Power steering
- Power brakes with rear anti-lock system
- Twin-I-Beam independent front suspension (4x2)
- Twin-Traction Beam independent front suspension (4x4)
- Heavy-duty nitrogen gas-pressurized shock absorbers
- Front and rear stabilizer bars
- Automatic locking front hubs and Touch Drive electric shift transfer case (4x4)
- Skid plates: fuel tank (4x2, 4x4) and transfer case (4x4)
- Frame-mounted full-size spare tire carrier

EXPLORER SPECIFICATIONS, DIMENSIONS, COLORS AND TRIMS

SPECIFICATIONS

Drivetrain	4x2 or 4x4
Engine type	4.0 liter V-6
Induction system	Multi-port electronic fuel injection with EEC-IV electronic engine controls
Horsepower, SAE net	155 @ 4200 rpm
Torque, SAE net	220 lbs.-ft. @ 2400 rpm
Compression ratio	9.0:1
Transmission	Std. 5-speed manual overdrive Opt. 4-speed automatic overdrive
Battery	72 AH; 650 CCA maintenance-free
Alternator	95 amps
Frame	Ladder-type, single channel with five crossmembers
Front suspension (4x2)	Twin-I-Beam axle, coil springs (computer-selected), gas-pressurized shocks, stabilizer bar
Front suspension (4x4)	Twin-Traction Beam axle, coil springs (computer-selected), gas-pressurized shocks, stabilizer bar
Rear suspension (4x2/4x4)	Semi floating-type rear axle (limited-slip differential optional), 2-stage variable-rate leaf springs (computer-selected), gas-pressurized shocks, stabilizer bar
4x4 front hubs/transfer case	Std. automatic locking hubs and Touch-Drive electric shift transfer case Opt. free-running manual locking hubs and part-time, 2-speed shift transfer case
Steering	Recirculating ball-type, power-assisted
Brakes	Power front discs/rear drums with computerized rear anti-lock system
Curb-to-curb turning diameter (ft.)	2-Door: 32.4 (4x2) 34.2 (4x4) 4-Door: 35.2 (4x2) 37.0 (4x4)
Wheels (type/size)	5-hole disc/15" x 6.0 JJ
Tires (see page 25 for applications)	P225 RBL all-season and P235 OWL all-terrain

EXPLORER 2-DOOR DIMENSIONS

	4X2	4X4
Wheelbase	102.1"	102.1"
Overall length	174.4"	174.4"
Overhang (front/rear)	29.6"/42.8"	29.6"/42.8"
Tread (front/rear)	58.3"/58.3"	58.3"/58.3"
Overall width	70.2"	70.2"
Width between wheelhouses	41.9"	41.9"
Overall height (empty — max.)	67.5"	68.5"
Step-in height (unloaded)	19.3"	20.1"
Load floor height (loaded)	25.5"	25.8"
Liftgate opening height	33.7"	33.7"
Axle clearance — loaded (rear)	6.3"	6.3"
Ground clearance at fuel tank skid plate — unloaded	—	7.3"
Angle of approach — loaded	28.4°	31.9°
Angle of departure — loaded	17.9°	17.2°
Ramp breakover angle — loaded	—	15.2°
Cargo length — rear seat up	29.2"	29.2"
— rear seat down	59.5"	59.5"
Cargo volume — rear seat up (cu. ft.)	32.6	32.6
— rear seat down	69.5	69.5
Seating capacity	4	4

XLT Deluxe two-tone paint: The accent color is applied below bodyside tape stripe at beltline and covers entire lower bodyside and tailgate. There are many color combinations to choose from. See your dealer for details.

EXPLORER 4-DOOR DIMENSIONS

	4X2	4X4
Wheelbase	111.9"	111.9"
Overall length	184.3"	184.3"
Overhang (front/rear)	29.6"/42.8"	29.6"/42.8"
Tread (front/rear)	58.3"/58.3"	58.3"/58.3"
Overall width	70.2"	70.2"
Width between wheelhouses	41.9"	41.9"
Overall height (empty — max.)	67.3"	67.3"
Step-in height (unloaded)	19.1"	20.1"
Load floor height (loaded)	26.1"	26.1"
Liftgate opening height	33.7"	33.7"
Axle clearance — loaded (rear)	6.3"	6.3"
Ground clearance at fuel tank skid plate — unloaded	—	9.5"
Angle of approach — loaded	28.3°	31.9°
Angle of departure — loaded	19.4°	18.7°
Ramp breakover angle — loaded	—	15.6°
Cargo length — rear seat up	38.1"	38.1"
— rear seat down	72.9"	72.9"
Cargo volume — rear seat up (cu. ft.)	42.6	42.6
— rear seat down	81.6	81.6
Seating capacity — Eddie Bauer	5	5
— XL, XLT	5 or 6*	5 or 6*

*Six-passenger seating with optional split bench front seat in XL and XLT 4-door models.

COLORS AND TRIMS

Interior Trim Colors				XL, Sport, XLT Exterior Colors
Medium Grey	Crystal Blue	Scarlet Red	Light Sandalwood	
X		X	X	Raven Black
X	X	X	X	Colonial White
X		X	X	Cabernet Red
X		X	X	Scarlet Red
X		X		Wild Strawberry Clearcoat Metallic
			X	Light Sandalwood
			X	Light Sandalwood Clearcoat Metallic
			X	Sandalwood Clearcoat Metallic
X	X			Crystal Blue Clearcoat Metallic
X	X			Twilight Blue Clearcoat Metallic
X		X		Shadow Grey Clearcoat Metallic
X	X	X		Silver Clearcoat Metallic
				Eddie Bauer Exterior Colors
			X	Raven Black*
			X	Cabernet Red*
			X	Wild Strawberry Clearcoat Metallic*
			X	Hunter Green Clearcoat Metallic*
			X	Twilight Blue Clearcoat Metallic*
			X	Sandalwood Clearcoat Metallic*

*With Light Sandalwood lower two-tone.



SAFETY AND OWNER BENEFITS

Ford Motor Company strongly encourages all passengers to use their safety belts. Ford also urges the use of child and infant restraints. Ford's easy-to-install Tot-Guard (for children 20 to 50 pounds) is available at all Ford Dealers. If a child restraint requires a top-tether, Explorer provides special anchorages.



FORD LIFEGUARD DESIGN SAFETY FEATURES

Vehicle operation

- Split service hydraulic brake system with warning light
- Corrosion-resistant brake lines
- Turn indicator with lane-changing signal feature
- Hazard warning flasher
- Backup lamps
- Parking lamps coupled with headlamps
- High-mount stop lamp
- Side marker lamps
- Windshield wipers with two constant speeds plus variable intermittent speeds
- Windshield washers
- Dual outside rearview mirrors
- Glare-reduced instrument panel, windshield wiper arms and windshield pillars
- Clutch or neutral starter motor interlock (on vehicles with manual transmission)
- Uniform transmission shift quadrant with safety starting switch (on vehicles with automatic transmission)
- Continuously variable control illumination intensity (instrument cluster lighting)
- Safety hood latch system
- Function-rated windshield defroster system
- Tamper-resistant (non-reversing) odometer
- Speedometer with highlighted 55 mph
- Impact-activated fuel pump shut-off switch for electronic fuel-injected engine

Occupant protection

- Safety-designed front end structure
- Side door intrusion beams
- Two-position door safety latches
- Integral lap and shoulder belts with automatic retractors for front and rear outboard occupants
- Lap belt for center front seat occupant with optional 60/40 split bench front seat and for center rear seat occupant (4-door model)
- Safety belt fastening reminder warning light and buzzer or chime for the driver's seat
- Energy-absorbing steering column and steering wheel
- Energy-absorbing armrests and safety-designed door handles
- Energy-absorbing instrument panel with padding for right front passenger (also center front with optional 60/40 split bench seat)
- Energy-absorbing sun visors
- Energy-absorbing front seat back tops
- Self-locking seat back latches (2-door model)
- Head restraints for front outboard occupants
- Safety

glove box latch Inside yieldaway rearview mirror Impact-absorbing laminated safety glass windshield Flame-resistant interior materials Safety-designed coat hook Safety-designed radio control knobs and push buttons

6-YEAR/60,000-MILE POWERTRAIN WARRANTY

Covers you and future owners with no transfer fee for 6 years or 60,000 miles, whichever comes first. This limited warranty covers listed powertrain components. Ask your dealer for a copy.

6-YEAR/100,000-MILE CORROSION PROTECTION

Corrosion warranty coverage for outer body panel rust-through is 6 years or 100,000 miles, whichever comes first. See your Ford Dealer for a copy.

SCHEDULED MAINTENANCE

Here are some examples of scheduled maintenance intervals for the 1991 Explorer. For complete maintenance recommendations, refer to the Explorer Scheduled Maintenance Booklet.

Engine oil and filter change	each 7,500 miles or 6 months
Spark plug change	each 30,000 miles
Air filter replacement	each 30,000 miles
Engine coolant replacement	each 30,000 miles or 3 years

FORD DEALER QUALITY COMMITMENT

The Ford Quality Commitment extends beyond the factory to every facility where Ford products are sold worldwide. Your Dealer knows that making your satisfaction his top priority is part of the total team effort. To him, "Quality is Job 1" means putting the customer first.



Participating Ford Dealers offer the Lifetime Service Guarantee (LSG), which guarantees their customer-paid work on your Ford vehicle for as long as you own it. A covered repair is paid for once. If it ever has to be fixed again, the repairing dealer will fix it free. For complete details, ask to see this Lifetime Service Guarantee when you visit your participating Ford Dealer.



Optional Ford Extended Service Plans cover major components on new Ford cars and trucks for longer than the vehicle's basic warranty. Your Ford Dealer has full details.



Genuine Ford and Motorcraft original equipment replacement parts meet the same high standards as those installed in production.



The leasing alternative is available to qualified lessees through your participating Ford Dealer, who can arrange financing terms or a Red Carpet LeaseSM tailored to your circumstances through Ford Credit. A variety of financing plans are also available.

Options availability

Options shown or described in this catalog are available at extra cost and may be offered only in combination with other options and subject to additional ordering requirements or limitations.

Product changes

Ford Division reserves the right to change product specifications at any time without incurring obligations.

"Ask your Ford Dealer"

Following publication of this catalog, certain changes in standard equipment, options, prices and the like, or product delays, may have occurred which would not be included in these pages. Your Ford Dealer is your best source for up-to-date information.



"Tread Lightly" is an educational program designed to increase public awareness of land-use regulations and responsibilities in our nation's wilderness areas. Ford joins the U.S. Forest Service and the Bureau of Land Management in encouraging you to help preserve our national forests and other public and private lands by "treading lightly."

